

»FUTURA« series

Activated carbon filters in modern design for compliance with strict compressed air purity requirements. Activated carbon filters are used to absorb oil vapour up to a residual oil content of 0.005 mg/m³ from compressed air and gases.

Input pressure	0 - 16 bar
Temperature range	-10 °C to 50 °C
Medium	Compressed air, neutral gases
Housing	PA66 GF60
Connecting thread	Material: Die-cast zinc
Filter element	Activated carbon
Residual oil content	0.005 mg/m ³
Flow rate measurement	At P ₂ = 6 bar and pressure drop Δ _p = 0.2 bar

Activated carbon filter with metal bowl and sight glass

Art. No.	Type No.	Thread	Size	Flow rate l/min
139512	FU 893-M	G 3/8	2	1700
139513	FU 894-M	G 1/2	2	1700

Accessories / spare parts

Art. No.	Type No.	Description
100043	H 852	Mounting bracket, incl. 2 screws
100044	WK 102	Wall bracket, incl. 2 screws
100045	KP 200	Joiner set, incl. 2 screws
100200	BSA 12	Polycarbonate bowl, incl. bowl guard
100201	MA 12	Metal bowl, incl. sight glass
100331	WK 102-38	Wall bracket with connection thread G 3/8
100332	WK 102-12	Wall bracket with connection thread G 1/2
100333	WK 102-34	Wall bracket with connection thread G 3/4
100202	A 894	Filter element (activated carbon)

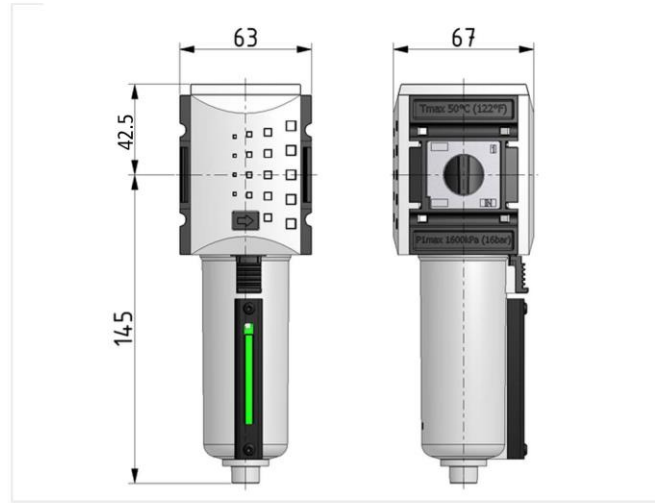

flow characteristic

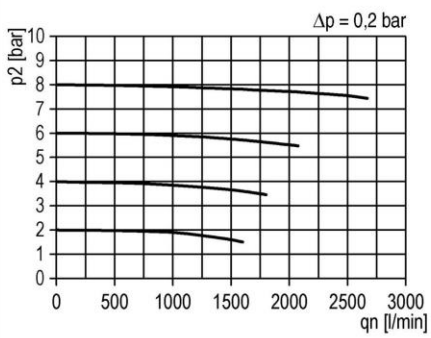

symbol

